



# OZ Optics

shop.ozoptics.com  
www.ozoptics.com



Elliot Scientific Ltd  
Unit 11 Sandridge Park,  
Porters Wood, St Albans,  
AL3 6PH, United Kingdom  
Tel: +44 (0)1582 766300  
Fax: +44 (0)1582 766340  
www.elliotscientific.com  
sales@elliotscientific.com

## POLARIZATION MAINTAINING FIBER PATCHCORDS AND CONNECTORS

### Features

- High extinction ratios of 20 dB up to 40 dB
- Low insertion losses, typically <0.2 dB
- Excellent repeatability
- Custom angles are available
- FC/PC, SC, LC, MU, E2000, MPO/MTP® terminations available
- Custom ferrule terminations available
- FC/PC terminations are offered with either a rotatable polarization axis, or pre-aligned fixed
- Compatible with industry standard connectors
- Designed to meet Telcordia specifications

### Applications

- High Speed Telecommunications
- Interferometric Sensors
- Integrated Optics
- Fiber Amplifiers
- Coherent Telecommunications

### Product Description

Polarization Maintaining (PM) patchcords are based on a high precision butt-style connection technique. The PM axis orientation is maintained by using male connectors with a positioning key and a bulkhead female receptacle with a tightly tolerated keyway, ensuring good repeatability in extinction ratios and insertion losses.



0.9 mm Jacketed PM Patchcords



3 mm Jacketed PM Patchcords

**NEW**



MPO/MTP® PM Fiber Assemblies



12 Fiber Connectors



16 Fiber Connectors

### Dual Fiber Polarization Maintaining Patchcords

A common requirement in polarizing devices is a fiber optic patchcord assembly where two or more polarization maintaining fibers are terminated in a single ferrule, to be attached to a lens or other optical assembly. Great care must be taken when assembling such devices, to ensure that the polarization axes of both fibers are precisely aligned with respect to each other.

OZ Optics has the capacity to manufacture dual fiber ferrule assemblies with high precision. The polarization axis of each fiber can be independently aligned, with the slow axes of the fibers aligned either parallel or perpendicular to each other. The end face of the ferrule can be flat or angle polished, to any desired orientation. Contact OZ Optics for details. For assemblies with more than two fibers, OZ Optics offers V-Groove assemblies. Please refer to the data sheet titled V-groove Assemblies for detailed information.

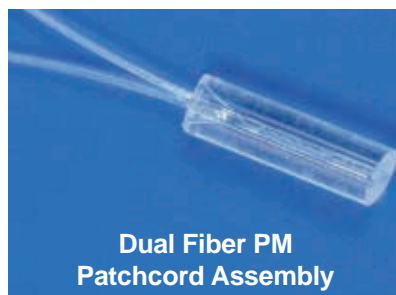

Dual Fiber PM Patchcord Assembly



End Face Of Dual Fiber Assembly Showing Stress Rod Alignment

The polarization axis of a fiber is aligned with the connector key by rotating either the connector frame or the fiber itself until the polarization axis is in line with keyway of the connector. Once the fiber is correctly aligned, the alignment can be fixed with a drop of glue or epoxy. OZ Optics minimizes backlash and rotational errors in the PM axis alignment by using specially designed PM ferrules and connector housings.

Patchcords are normally offered prealigned and referenced with the slow axis aligned to the connector key for optimum coupling efficiency and extinction ratios. Non-angled FC PM connectors are also available unaligned and unlocked (rotatable) for lab use. Unless otherwise specified, prealigned patchcords are oriented such that the slow axis of the fiber is aligned with the key of the connector and locked, as shown in figure 5. These patchcords maintain polarization to better than 20 dB. Higher extinction ratios are available upon request.

In general, OZ Optics uses polarization maintaining fibers based on the PANDA fiber structure when building polarization maintaining components and patchcords. However OZ Optics can construct devices using other PM fiber structures. This includes patchcords with 80 micron cladding sizes. We do carry some alternative fiber types in stock, so please contact our sales department for availability. If necessary, we are willing to use customer supplied fibers to build devices.

OZ Optics uses a 2.00 mm housing key for its standard FC/PC PM connector design. This is known also as a type "R" keywidth. Also available are FC/PC connectors with a 2.14 mm housing keys (Type "N"). Sleeve through adaptors are available to connect same size keys or to convert from a 2.00 mm key connector to a 2.14 mm key connector.

In addition to patchcords and sleeve through adaptors, OZ Optics provides male PM connectors and ferrules for fiber termination, and bulkhead receptacles to attach fibers to devices. We have ferrules for different fiber sizes, including 80 micron cladding sizes. OZ Optics can satisfy all your polarization maintaining fiber needs.

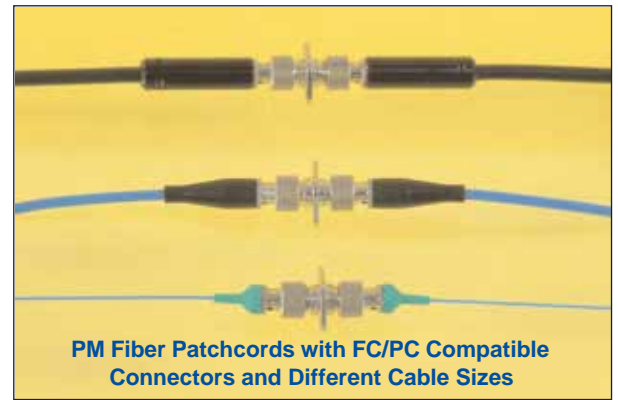

PM Fiber Patchcords with FC/PC Compatible Connectors and Different Cable Sizes



PM connector-E2000

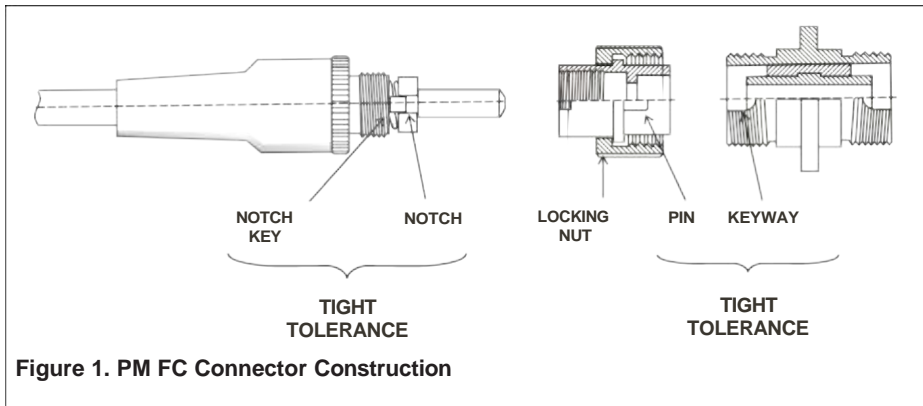

Figure 1. PM FC Connector Construction

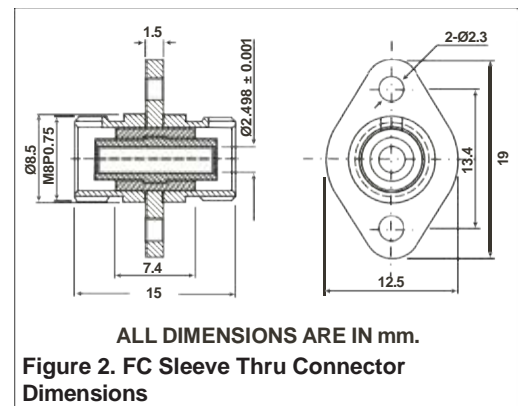

Figure 2. FC Sleeve Thru Connector Dimensions

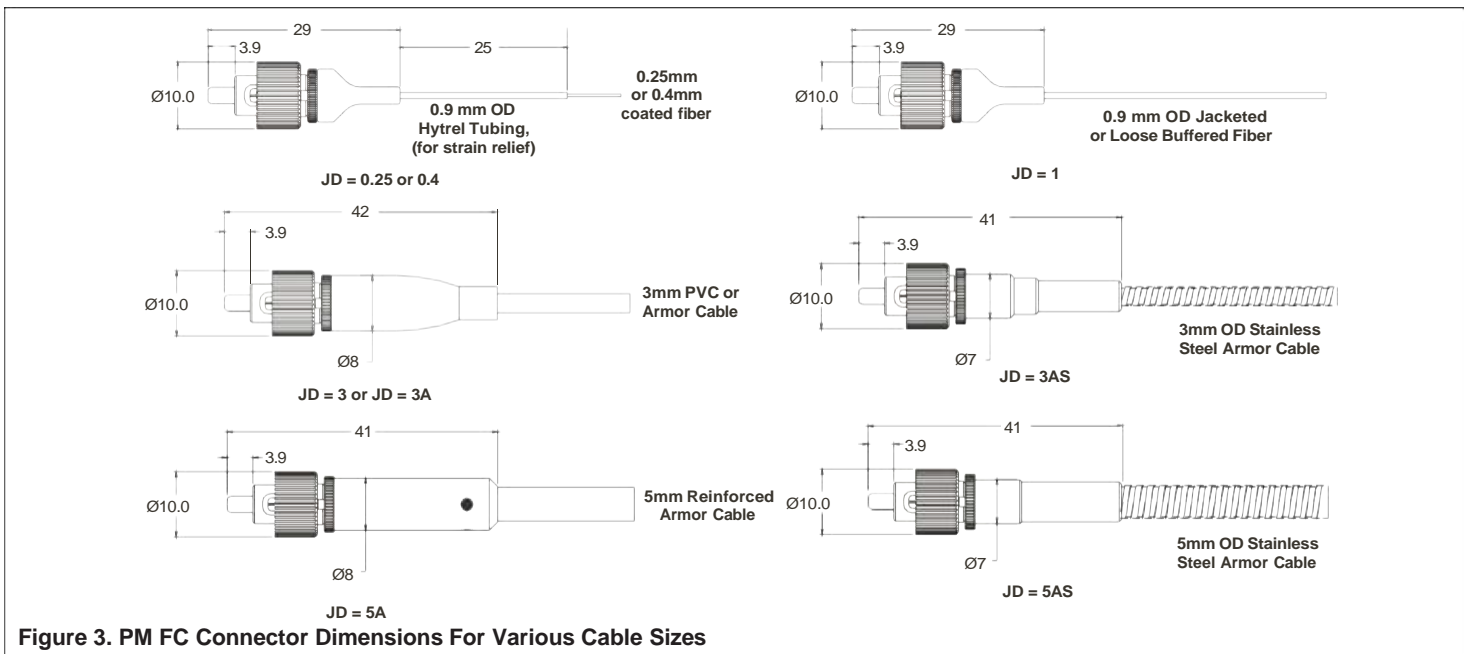
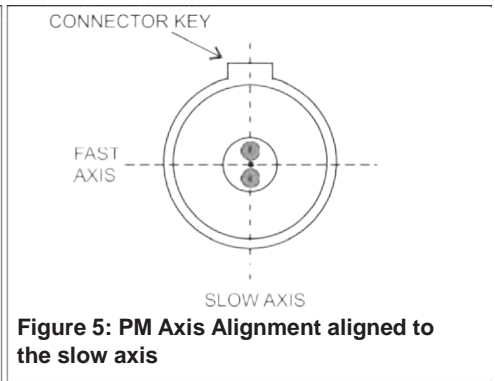
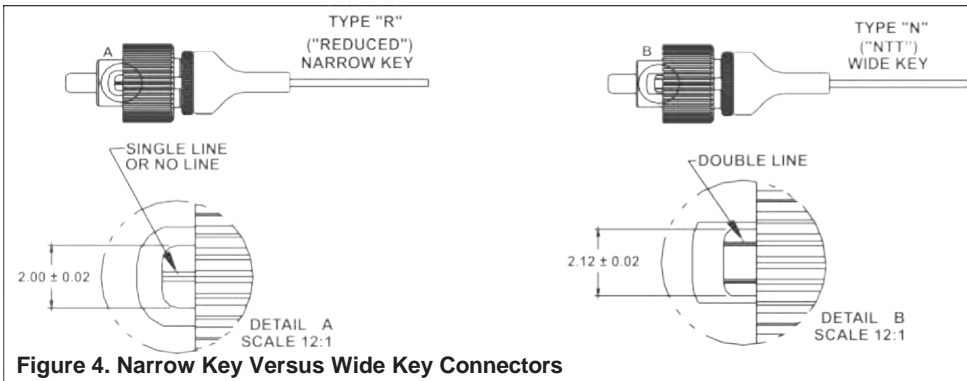
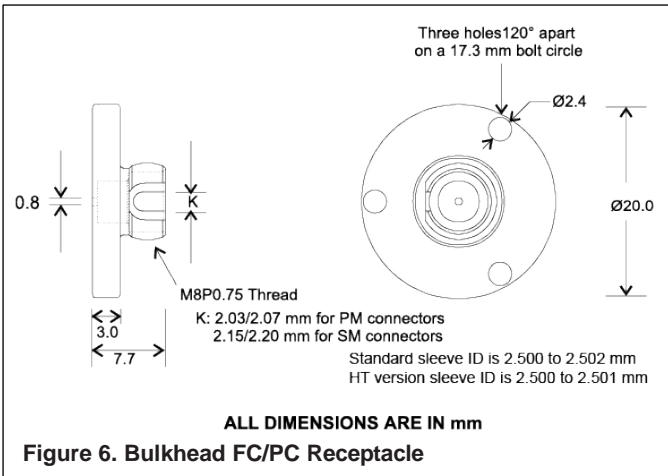

Figure 3. PM FC Connector Dimensions For Various Cable Sizes



**Figure 5: PM Axis Alignment aligned to the slow axis**



**Figure 6. Bulkhead FC/PC Receptacle**

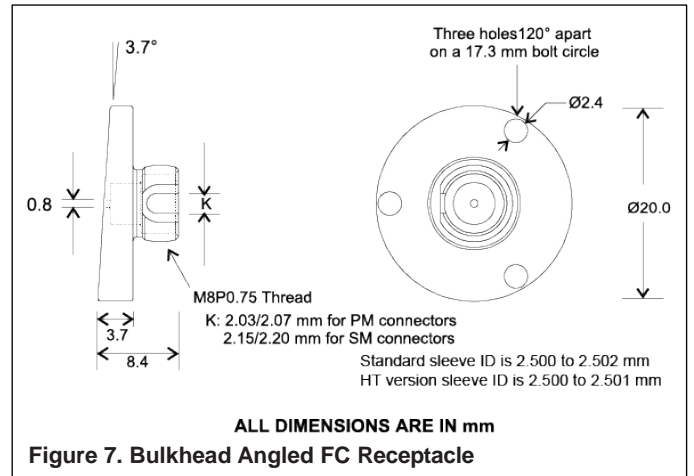

**Figure 7. Bulkhead Angled FC Receptacle**

**Standard Product Specifications:**

Design Wavelength	1550 nm	1300 nm	980 nm	850 nm	633 nm	488 nm	
Operating Wavelength Range	1460-1625	1290-1550	980-1300	810-980	620-820	480-630	
Cutoff Wavelength	<1450	<1280	<970	<800	<620	<470	
Fiber Type	PANDA structure standard. Other fiber types available on request						
Fiber Core/Cladding Size (microns)	8/125	7/125	6/125	5/125	4/125	3.5/125	
Insertion Loss <sup>1,3</sup>	Maximum	0.4 dB	0.45 dB	0.6 dB	0.75 dB	1.25 dB	1.5 dB
	Typical	<0.2 dB	<0.3 dB	<0.4 dB	<0.5 dB	<0.9 dB	<1.2 dB
Backreflection <sup>2,3</sup>	-14 Typical with flat finish, -40 with Super PC finish, -50 with Ultra PC finish, and -60 for angle point contact (APC), and angle flat contact (AFC) finishes.						
Minimum Extinction Ratios (dB) <sup>4</sup>	20, 25, 30, 35, 40	20, 25, 30, 35	20, 25	20, 25	20	18	
Polarization Angle Tolerance <sup>5,6</sup>	±3 degrees (standard grade), ±1.5 degrees (high grade)						
Temperature Range	-20 °C to +70 °C Operating -40 °C to +85 °C Storage						
Length Tolerance	±0.1 m or 10% of length, whichever is larger (Tighter tolerances possible on request)						

<sup>1</sup> As measured using FC connectors, with Super PC Finish. For APC Connectors add 0.1 dB. For MPO & MT typical IL 0.20, max 0.70 dB and typical ER ≤25 dB, min 20 dB for 1300 & 1550 nm wavelengths

<sup>2</sup> As measured for 1300 nm and 1550 nm wavelengths. Return losses at other wavelengths are estimated only.

<sup>3</sup> As measured when mating to a matching connector.

<sup>4</sup> Defined as the extinction ratio of the patchcord itself. Does not include the effect of connecting two fibers together.

<sup>5</sup> Normally defined as the angle of the optimum polarization as referenced against the connector key. For 488 nm, the angle is defined as the angle between the fiber stress rods and the connector key instead.

<sup>6</sup> For FC style connectors only. Angle tolerances are somewhat looser for other connector types.

## Ordering Information For Custom Parts:

OZ Optics welcomes the opportunity to provide custom designed products to meet your application needs. As with most manufacturers, customized products do take additional effort so please expect some differences in the pricing compared to our standard parts list. In particular, we will need additional time to prepare a comprehensive quotation, and lead times will be longer than normal. In most cases non-recurring engineering (NRE) charges, lot charges, and a 1 piece minimum order will be necessary. These points will be carefully explained in your quotation, so your decision will be as well informed as possible. We strongly recommend buying our standard products.

## Questionnaire For Custom Parts:

1. What is the wavelength that you need to operate at?
2. What type of connector or receptacle are you going to connect to?
3. What jacket diameter/construction is needed for your application?
4. What is the required Extinction Ratio needed?
5. Is backreflection a concern for your application?
6. Is this going to be used with a source over 250mW?
7. Is there any special requirements needed for this assembly?

## Polarization Maintaining Patchcords:

**PMJ-XY-W-a/b-JD-L-A-(OPT)**

**P** = PM fiber type

QP for pure fused silica core PM fibers (488 nm only). P for standard doped core PM fibers

**XY** = Connector Code (Side A, SideB)  
 3S = Super FC/PC (<-40 dB RL)  
 3U = Ultra FC/PC (<-50 dB RL)  
 3A = Angle FC/PC (<-60 dB RL)  
 8 = ST  
 SC= Super SC (<-40 dB RL)  
 SCU = Ultra SC (<-50 dB RL)  
 SCA = Angle SC (<-60 dB RL)  
 LC = LC  
 LCA = Angle LC  
 MU = MU  
 MPO(m) = MPO male  
 MPO(f) = MPO female  
 MPOA(m) = MPO male angle polished  
 MPOA(f) = MPO female angle polished  
 MT(m) = MT male PC ferrule  
 MT(f) = MT female PC ferrule  
 MTA(m) = MT / angle male ferrule  
 MTA(f) = MT / angle female ferrule  
 X = No Connector  
 See Table 6 of the standard tables data sheet for other connectors

**W** = Wavelength, in nanometers  
 (488, 633, 850, 980, 1300, or 1550)

**a/b** = fiber core/cladding parameters  
 3.5/125 for 488 nm PM fiber  
 4/125 for 633 nm PM fiber  
 5/125 for 850 nm PM fiber  
 6/125 for 980 nm PM fiber  
 7/125 for 1360 nm PM fiber  
 8/125 for 1550 nm PM fiber

**OPT** = Add -ER=25 for minimum Extinction Ratio of 25 dB  
 Add -ER=30 for minimum Extinction Ratio of 30 dB  
 Add -WK for 2.14mm wide keys  
 For MPO & MT only  
 Add - 12 for 12 channel version  
 - 16 for 16 channel version  
 Add "KD" (key-down) version  
 Add "B" for Type B version  
 \* Our standard MPO has key-down version and standard polarity is Type A

**A** = Alignment for PM terminations  
 0 = unaligned and rotatable  
 1 = Slow axis of the PM fiber aligned with respect to the key and locked.

**L** = Overall assembly length in meters

**JD** = Jacket Diameter  
 0.25 = 250 micron acrylate coating  
 0.40 = 400 micron acrylate coating  
 1 = 900 micron OD Hytel loose tube buffered fiber  
 3 = 3 mm OD loose tube Kevlar  
 3A = 3 mm OD armored  
 3AS = 3 mm OD stainless steel armored  
 5A = 5 mm OD armored  
 5AS = 5 mm OD stainless steel armored

Type A cable, also known as straight cable, is a straight-through cable with a key-up MPO connector on one end and a key-down MPO connector on the opposite end. This makes the fibers at each end of the cable have the same fiber position. For example, the fiber located at position 1 (P1) of the connector on one side will arrive at P1 at the other connector. The fiber sequence of a 12 fiber Type A MPO cable is shown below:

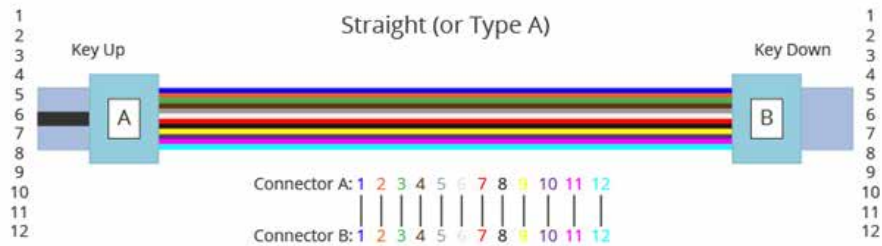

MPO Trunk Cable Type B: Type B cable (reversed cable) uses key-up connectors on both ends. This type of array mating results in an inversion, which means the fiber positions are reversed at each end. The fiber at P1 at one end is mated with the fiber at P12 at the opposing end. The following picture shows the fiber sequences of a 12 fiber Type B cable.

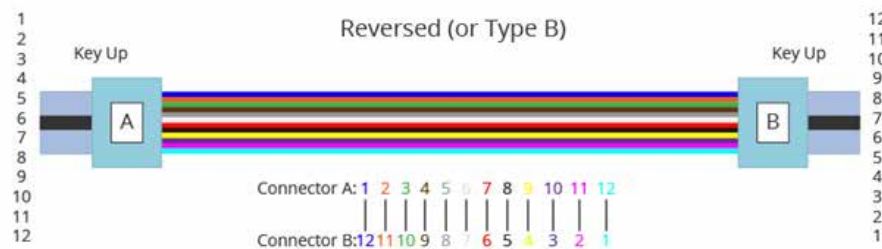

**PM FC Connectors (consists of housing and ferrule):**

- X** = Connector Code
- 3 = FC, flat endface, black boot
- 3S = FC, radiused endface, black boot
- 3U = FC, radiused endface, blue boot
- 3A = FC, conical tip flat endface, Green Boot

**b** = Ferrule Hole Size in microns<sup>2</sup>  
 Available hole sizes: 80, 81, 82, 83, 84, 124, 125, 126, 127, 128

**Notes:**

- <sup>1</sup> Add -WK to the end of the part number for a 2.14 mm wide key.
- <sup>2</sup> Hole Size Tolerance: +1/-0 microns.
- <sup>3</sup> For MPO & MT connector ferrules typical ER=25dB, min. ER=20dB for 1300 & 1500 nm.

**PMPC-2X-b-JD-(WK)<sup>1</sup>**

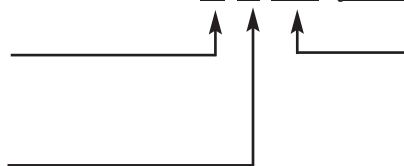

- JD** = Jacket Diameter
- 1 = 1 mm OD jackets or smaller
- 3 = 3 mm OD loose tube kevlar
- 3A = 3 mm OD armored
- 3AS = 3 mm OD stainless steel armored
- 5A = 5 mm OD armored
- 5AS = 5 mm OD stainless steel armored

**PM FC Ferrules:**

- F** = Ferrule Finish
- F for flat endface finish
- S for radiused endface finish

**b** = Ferrule Hole Size in microns<sup>1</sup>  
 Available hole sizes: 80, 81, 82, 83, 84, 124, 125, 126, 127, 128

**Notes:**

- <sup>1</sup> Hole Size Tolerance: +1/-0 microns.

**PMF-b-(JD)-(APC)**

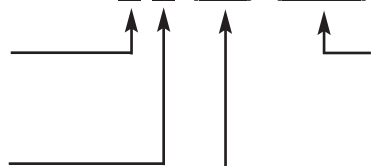

- APC** = Conical Tip for APC connectors
- APC for Conical Tip
- Leave blank for standard tips.

- JD** = Jacket type design
- Add "-LF-3.0" for flanges designed for 3 mm loose tube Kevlar cable
- Leave blank for all other cable types

## Ordering Examples for Custom Parts:

### Example 1:

A customer needs to connect a polarized 1550 nm laser source with a Angle SC receptacle to another device which has an Angle LC receptacle. Both of the connectors are to be aligned with the key to the slow axis. The patchcord needs to be 4.75 meters long and 2 mm jacketed to prevent damage during handling.

Bar Code	Part Number	Description
NEW	PMJ-SCALCA-1550-8/125-2-4.75-1	Patchcord, Angle SC to Angle LC, 8/125 um PM 1550 nm fiber, 2 mm OD PVC jacketed, 4.75 meters long with connectors aligned and locked to the slow axis

### Example 2:

A customer needs a polarization maintaining patchcord for 1550 nm, capable of maintaining at least 25 dB. The cables need to be 1.5 meters long, with 3mm OD jacketing, and terminated with FC/PC connector, with Ultra PC finish. He needs wide key connectors on the fibers to match his existing hardware. He also wants the matching sleeve through connector and bulkhead female receptacle.

Bar Code	Part Number	Description
N/A	PMJ-3U3U-1550-8/125-3-1.5-1-ER=25-WK	1.5 meter long, 3 mm OD jacketed, 1550 nm 8/125 PM fiber patchcord, terminated on each end with ultra FC/PC connectors that are prealigned and locked to the slow axis. ER=25 dB minimum. WK: 2.14mm wide keyway
21	HPLC-NTT/FC-SM	Flanged bulkhead receptacle for singlemode or polarization maintaining connectors. Key way width is 2.15/2.20mm for 2.14 mm wide (Type N) connectors.
1812	SMPC-03	Flanged sleeve thru connector for singlemode or polarization maintaining connectors. Key way width is 2.15/2.20 mm for 2.14 mm wide (Type N) connectors.

### Example 3:

A client has a polarization maintaining fiber with normally an 80 micron cladding diameter, but the actual size can vary from 80 to 82 microns. He wishes to terminate the fibers with Ultra FC/PC connections. The fiber is uncabled. For economy, he wishes to buy the ferrules and housings separately. The required part numbers are as follows:

Bar Code	Part Number	Description
13623	PMPC-02U-1	PM FC housing, narrow key, with a blue boot for 1 mm OD or smaller jacketing.
N/A	PMS-80	PM FC Ferrule for Super PC or Ultra PC finish connectors, with 80 micron hole, for 1 mm OD or smaller jacketing.
N/A	PMS-81	PM FC Ferrule for Super PC or Ultra PC finish connectors, with 81 micron hole, for 1 mm OD or smaller jacketing.
N/A	PMS-82	PM FC Ferrule for Super PC or Ultra PC finish connectors, with 82 micron hole, for 1 mm OD or smaller jacketing.



**Elliot Scientific Ltd**  
Unit 11 Sandridge Park,  
Porters Wood, St Albans,  
AL3 6PH, United Kingdom  
Tel: +44 (0)1582 766300  
Fax: +44 (0)1582 766340  
www.elliotscientific.com  
sales@elliotscientific.com

## Frequently Asked Questions (FAQs):

**Q:** Can fibers be aligned other than the slow axis to the key?

**A:** Yes, OZ Optics can align connectors to the fast axis on one or both ends. The patchcords with non-angled FC connectors are also available unlocked allowing the user to align them to any angle required.

**Q:** Can extinction ratios of higher than 30 dB be achieved?

**A:** Yes. Please contact OZ Optics for more information

**Q:** Why is your best angle tolerance  $\pm 1.5$  degrees? Can you do better?

**A:** Two things limit the accuracy of the angular alignment: the mechanical tolerances within the connectors, and the optical tolerances of the test systems. While PM connectors are made to the tightest possible tolerances, there must be some room to allow the ferrule to move. This room accounts for about a degree of play. Optically, the polarization tooling developed by OZ can achieve readings accurate to within 0.5 degrees. Combined, this gives the 1.5 degree angle tolerance.

**Q:** Can lengths other than full meter lengths be ordered?

**A:** Yes, lengths can be specified as a standard to one decimal point (ie 3.2 meters) in the part number.

**Q:** Can PM fiber for 1300 nm be used for 1550 nm? How about the other way around?

**A:** PM fiber for 1300 nm will work at 1550 nm, although it will be more sensitive to bending and stress. However, the cut off wavelength for 1550 nm PM fiber is usually longer than 1300 nm, so it will generally not work properly at 1300 nm.

**Q:** I want to use PM patchcords with 1480 nm light. What fiber do I use?

**A:** If you refer to the standard product specifications, you see that the standard 1550 nm PM fiber operates wavelengths as short as 1460 nm. So select this wavelength patchcord. Similarly, 980 nm PM patchcords can be used at 1064 nm, and 488 nm PM patchcords will operate at 532 nm.

**Q:** I'm using a white light laser. Can I use the same PM patchcord to transmit both 488 nm and 633 nm light?

**A:** Not every lot of 488 nm PM fiber works at 633 nm, so one should be careful to specify this when ordering. A good fiber lot can then be selected as a special order. A special part number will be given to reflect this.

**Q:** Can OZ Optics terminate fibers with cladding diameters other than 125 microns?

**A:** Yes we can. We have ferrules designed to accommodate fibers with nominally 80 microns or 125 microns. For the 80 micron size range we have specific ferrules with 80, 81, 82, 83, and 84 micron hole sizes. In the 125 micron size range, we have ferrules with 124, 125, 126, 127, and 128 micron hole sizes. This allows us to ensure that the connectors and ferrules match as closely as possible, ensuring low losses.

**Q:** What should the minimum length be for PM patchcords?

**A:** The patchcord should be long enough to successfully attenuate any light that is unintentionally launched into the cladding instead of the core. Light in the cladding will not maintain polarization and could disrupt your readings. For infrared wavelengths, any length longer than about 0.3 meters is acceptable. However, the fibers normally used for 488 nm and 633 nm wavelengths tend to support light in the cladding over much longer distances. We recommend ordering patchcords at least two meters long for visible applications.

**Q:** What about a maximum length?

**A:** Most patchcords manufactured by OZ are no longer than 50 meters. Longer patchcords can be made, but not with 30 dB extinction ratios. Over very long lengths random variations in the fiber properties limit the extinction ratio the fiber can maintain.

**Q:** Is there some way to improve the extinction ratio from my current patchcord/pigtailed source?

**A:** The easiest way is with a fiber optic polarizer. This device contains a polarizing optic aligned to the slow axis of the fiber. The unwanted polarization is blocked, leaving only light polarized the correct way. Extinction ratios can be improved to exceed 30 dB using this technique. Note however that you will see a small power loss and some minor fluctuations in the output power with this method. Please see the data sheet titled Fiber Optic Polarizers for more information.

**Q:** Why are there narrow keys and wide keys? Why is this important?

**A:** The role of the key is to ensure proper mating and limit rotation of the fiber within the connector to ensure good repeatability. The connector key and key way receptacle keyway need to be well matched to achieve good repeatability and high extinction ratios across a connector. Similarly in angles polished connectors, the rotation must be minimized to prevent excessive losses.

When the FC connector design was first developed, the tolerances for the key and keyway were rather loose. The key on the connector could be as small 2 mm, while the keyway could be as large as 2.15 mm. This is not tight enough for either PM or angle connector requirements.

Two approaches were considered. One involved reducing the size of the keyway (the "Reduced" standard), while the other was to enlarge the key (the "NTT" standard). Unfortunately the industry was unable to agree top a single standard. Thus the consumer must be aware of both. It is important to ensure that all devices in your setup match. A connector with a narrow key will fit into a wide key receptacle, but will give poorer performance. A connector with a wide key will not fit into a narrow receptacle and forcing the part in will likely damage both the connector and the receptacle.

OZ Optics normally used the narrow key tolerances in its products, although wide key products can be provided on request.

**Q:** So how can I tell the two standards apart?

**A:** On OZ Optics PM connectors, the keys have been marked with an identifying scribe (Refer to Figure 4). Keys with either no scribe mark or a single scribe mark have been made to the narrow key tolerance. Keys with two scribe marks have been made to the wide key tolerance. This makes an easy way to recognize the difference.

Unfortunately this standard is not universally used. To be absolutely sure, the best way is to measure the key and the keyway in question with a caliper. Table 8 gives the connector tolerance specifications.

**Q:** Help! I have fibers with narrow keys and fibers with wide keys! What do I do?

**A:** OZ Optics does offer a sleeve-thru adapter the allows one to connect a narrow key connector to a wide key connector, provided the two connectors have the same polish style (Part number PMPC-03-2.14, Bar Code 3619)

## Frequently Asked Questions (cont.):

**Q:** What is the difference between FC, Super FC/PC, Ultra FC/PC and FC/APC?

**A:** The basic difference in the specifications for the FC/PC terminations is the Return Loss. The same basic connector design is used for all of the different types. The return loss specifications for the different connector polish types are:

FC typically -14 dB

Super FC/PC <-40 dB

Ultra FC/PC <-50 dB

FC/APC (8 degree angle polished FC/PC) <-60 dB

The Super FC/PC and Ultra FC/PC are compatible with each other. The best return loss you will get however is that of the worst reading connector (ie if you connect a Super FC/PC to an Ultra FC/PC you should only expect a return loss of <-40 dB.

The FC/APC (angle polished) connector can not be mated to a standard polished connector (FC/PC, Super or Ultra). The fibers will not contact and light will not be transmitted. They can however be connected to the angle polished FC connectors.

## Application Notes:

### Polarization Maintaining Fibers:

When a normal fiber is bent or twisted, stresses are induced in the fiber. These stresses in turn will change the polarization state of light traveling through the fiber. If the fiber is subjected to any external perturbations, say changes in the fiber's position or temperature, then the final output polarization will vary with time. This is true for even short lengths of fiber, and is undesirable in many applications that require a constant output polarization from the fiber.

To solve this problem, several manufacturers have developed polarization maintaining fibers (PM fibers). These fibers work by inducing a difference in the speed of light for two perpendicular polarizations traveling through the fiber. This birefringence creates two principal transmission axes within the fiber, known respectively as the fast and slow axes of the fiber. Provided the input light into a PM fiber is linearly polarized and orientated along one of these two axes, then the output light from the fiber will remain linearly polarized and aligned with that axis, even when subjected to external stresses. A one meter long connectorized patchcord constructed with PM fiber can typically maintain polarization to at least 30 dB at 1550 nanometers when properly used.

Naturally, how well a PM fiber maintains polarization depends on the input launch conditions into the fiber. Perhaps the most important factor is the alignment between the polarization axis of the light with the slow axis of the fiber. Assume that we have a perfectly polarized input beam into an ideal fiber, misaligned by an angle  $\theta$  with respect to the slow axis of the fiber. (See Figure 8) The maximum possible value of the output extinction ratio is thus limited by:

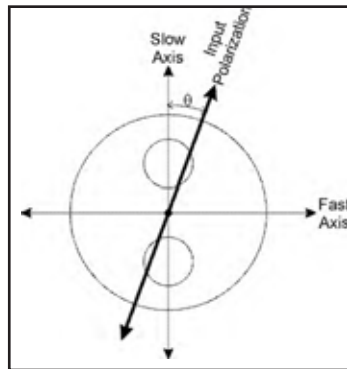

**Figure 8: Angular Alignment Mismatch Between Polarized Light and Fiber**

$$ER \leq -10 \log (\tan^2\theta)$$

Thus to achieve output extinction ratios greater than 20 dB, the angular misalignment must be less than 6 degrees. For 30 dB extinction ratios, the angular misalignment must be less than 1.8 degrees.

The polarization extinction ratio can be degraded by any stresses or microbends in the connectors, or by external optical components that do not maintain polarization properly. Special termination procedures, stress free glues, and top quality lenses and optics must be used to minimize these stresses and thus maintain the highest possible extinction ratios.



**Elliot Scientific Ltd**  
Unit 11 Sandridge Park,  
Porters Wood, St Albans,  
AL3 6PH, United Kingdom  
Tel: +44 (0)1582 766300  
Fax: +44 (0)1582 766340  
www.elliotscientific.com  
sales@elliotscientific.com

### Polarization Maintaining Connectors:

Given the importance of the alignment of the PM axis across a connection, the choice of connector is especially important. The most common type of PM connector in use is a variation of the NTT-FC style connector. FC connectors have a positioning key, to preserve the angular orientation of the fiber. The industry standard is to align the slow axis of the fiber with the connector key.

The tolerances between the key and keyway on standard FC connectors are too loose to accurately maintain angular alignment, so manufacturers have tightened the key dimension tolerances on PM connectors. The key dimensions being used are based on FC angle polished connector (APC) standards. Unfortunately, two APC standards are currently on the market, a narrow, or reduced key design, and a wide key design. The two dimensions are incompatible with one another, so it is important to know beforehand which design you are using. Table 9 lists the key dimensions for these standards.

Connector Type	Key Width (mm)	Keyway Width (mm)
R (Reduced)	1.97-2.02	2.03-2.08
N (Wide)	2.09-2.14	2.15-2.20

**Table 9: Connector Key Tolerances**

As the marketplace evolves, PM patchcords using other connector types are beginning to appear. For instance, SC connectors are becoming a more popular choice. In all cases, there must be a key or similar structure to act as a reference, and tight tolerances must be kept to ensure that the ferrules cannot rotate.

### Testing Polarization Maintaining Patchcords:

Suppose we want to test a device, such as a patchcord, to determine both the device performance and the connector quality. To do so you need the following equipment:

- A highly polarized source, preferably at least 30 to 40 dB. The source should provide at least 0.1 mW of useful optical power, and have a means to rotate the orientation of the output polarization, and indicate the output angle. OZ Optics provides polarized fiber optic sources (PFOSS) and highly stable polarized fiber optic sources (HIPFOSS), which meet these requirements.
- A polarization extinction ratio meter. Such a meter measures both the polarization extinction ratio and polarization axis of the output light. Alternatively, a rotatable polarizer, with an angle readout can be used to perform the same operation manually. OZ Optics offers both extinction ratio meters and manual polarization analyzers for these measurements.
- A reference patchcord, able to maintain polarization to at least 30 dB, to check the measurement system, and to test the PM connector characteristics.
- A compatible polarization maintaining bulkhead receptacle, to check the connector characteristics.
- A mandrel, about 50 mm in diameter, to wrap the fiber around, in order to stress the fiber to stimulate external perturbations. Alternatively, one could also use a heat source, such as a warming plate.
- (Optional) One or more bare fiber adaptors, to attach unterminated fibers to either the source or the extinction ratio meter.

OZ Optics can supply entire test setups, consisting of a highly polarized source, an extinction ratio meter, and a reference patchcord. Refer to the data sheet titled "Fiber Optic Polarization Extinction Ratio Measurement System" for more information.



**Elliot Scientific Ltd**  
Unit 11 Sandridge Park,  
Porters Wood, St Albans,  
AL3 6PH, United Kingdom  
Tel: +44 (0)1582 766300  
Fax: +44 (0)1582 766340  
www.elliotscientific.com  
sales@elliotscientific.com