



OZ Optics

shop.ozoptics.com
www.ozoptics.com



Elliot Scientific Ltd
Unit 11 Sandridge Park,
Porters Wood, St Albans,
AL3 6PH, United Kingdom
Tel: +44 (0)1582 766300
Fax: +44 (0)1582 766340
www.elliotscientific.com
sales@elliotscientific.com

ELECTRICALLY CONTROLLED VARIABLE FIBER OPTIC ATTENUATOR

Features

- Stepper motor driven
- High power handling
- High speed
- Wide attenuation range (from 350-2050nm)
- Low PDL and wavelength dependency
- Low insertion loss and backreflection
- High resolution
- Rugged and compact design
- Can be calibrated for up to five wavelengths
- Wide wavelength range
- Flat wavelength response
- Blocking attenuation technique for singlemode and polarization maintaining fibers, neutral density filter for multimode fiber applications
- Computer interface (-MC Version)
- Polarization maintaining fiber versions are available.
- Latching operation
- Custom designs available
- Low Cost

Applications

- Active gain equalization in DWDM Systems
- Local power monitoring and feedback attenuator settings
- Bit error testing
- Trouble shooting receivers and other active fiber optic components
- Simulating long distance fiber transmission
- Design of fiber optic transmitter/receiver circuitry
- Power meter linearity checks
- Power setting and power control
- OCT systems

Product Description

OZ Optics offers a complete line of low cost, compact PC board mountable motor driven variable attenuators with low backreflection. These attenuators offer excellent speed, repeatability, and accuracy. Singlemode and polarization maintaining (PM) attenuators utilize a novel blocking style attenuation technique, while multimode attenuators use a variable neutral density filter to minimize mode dependent losses. Both types feature a homing sensor to calibrate the attenuator, removing the need to use external taps, and a jam-proof tuning mechanism.

In general, OZ Optics uses polarization maintaining fibers based on the PANDA fiber structure when building polarization maintaining components and patchcords. However OZ Optics can construct devices using other PM fiber structures. We do carry some alternative fiber types in stock, so please contact our sales department for availability. If necessary, we are willing to use customer supplied fibers to build devices.

The PC version uses a reliable stepper motor that can be controlled by an external driver. The basic model provides the user direct access to the stepper motor, as well as a logic level output for HOME position information. The -DR option adds a high speed driver circuit that accepts four logic level inputs to control the stepper motor. Finally, the -MC option features an embedded microcontroller with a programmed calibration curve. The units are addressable and support RS232, SPI, or I²C communication protocols. At this time, electronically controlled miniature loopback models are available only in PC versions.

The MC version attenuators are calibrated at the wavelength specified in the part number. If required, the attenuators can be calibrated for multiple wavelengths. Just specify them in the part number.

The standard models utilize a stepped motor with a 485:1 antibacklash gear train. Other gear ratios are available to increase either the speed or resolution of the device. Keep in mind that choosing lower gear ratios to improve the speed will reduce the resolution of the device.

OZ Optics can also customize the design to fit your needs. **We have smaller and faster versions if lower resolution is acceptable.** Please read our application notes on our website. Contact OZ Optics for detailed specifications.



Motor Driven Variable Attenuator



OEM Motorized Attenuator



Loopback Style Motorized Attenuator

Ordering Information For Standard Parts:

Bar Code	Part Number	Description
14170	DD-100-11-1300/1550-9/125-S-40-XX-3-1-485:1-6	Electrically controlled variable attenuator at 1300/1550nm with 1m long, 3mm OD jacketed 9/125 micron unterminated singlemode fiber on both ends and 40dB return loss. Unit comes with TTL compatible home signal.
14171	DD-100-11-1300/1550-9/125-S-40-XX-3-1-485:1-6-DR	Electrically controlled variable attenuator at 1300/1550nm with 1m long, 3mm OD jacketed 9/125 micron unterminated singlemode fiber on both ends and 40dB return loss. Unit comes with built in stepper motor drive electronics.
14173	DD-100-11-1300/1550-9/125-S-40-XX-3-1-485:1-6-MC/IIC	Electrically controlled variable attenuator at 1300/1550nm with 1m long, 3mm OD jacketed 9/125 micron unterminated single mode fiber on both ends and 40dB return loss. Unit to be calibrated at 1300/1550nm and comes with I ² C interface
14172	DD-100-11-1300/1550-9/125-S-40-XX-3-1-485:1-6-MC/RS232	Electrically controlled variable attenuator at 1300/1550nm with 1m long, 3mm OD jacketed 9/125 micron unterminated singlemode fiber on both ends and 40dB return loss. Unit to be calibrated at 1300/1550nm and comes with RS/232 interface
8924	DD-100-11-1300/1550-9/125-S-50-3U3U-1-1-485:1-6-PC	Electrically controlled variable attenuator with 1m long , 0.9mm OD jacketed singlemode fiber with FC/Ultra PC connectors on both ends and 50dB return loss. PC: OEM version, no electronics and no calibration.
9749	DD-100-11-1300/1550-9/125-S-50-3U3U-3-3-485:1-6-MC/RS232-LL	Electrically controlled variable attenuator with 3m long , 3mm OD jacketed singlemode fiber with FC/Ultra PC connectors on both ends and 50dB return loss. Unit to be calibrated at 1300/1550nm and comes with RS232 interface. IL≤1dB
11825	DD-100-11-1300-7/125-P-50-3U3U-3-1,3-485:1-6-MC/RS232-LL	Electrically controlled variable attenuator with 1m long input, 3m long output, 3mm OD jacketed PM fiber with FC/Ultra PC connectors on both ends and 50dB return loss. Unit to be calibrated at 1300nm and comes with RS232 interface. IL≤1dB
9800	DD-100-11-1300-7/125-P-50-SCUSCU-1-1-485:1-6-MC/RS232	Electrically controlled variable attenuator with 1m long , 0.9mm OD jacketed PM fiber with SC/Ultra PC connectors on both ends and 50dB return loss. Unit to be calibrated at 1300nm and comes with RS232 interface.
14174	DD-100-11-1550-8/125-P-40-XX-3-1-485:1-6	Electrically controlled variable attenuator at 1550nm with 1m long, 3mm OD jacketed 8/125 micron unterminated PM fiber on both ends and 40dB return loss. Unit comes with TTL compatible home signal
14175	DD-100-11-1550-8/125-P-40-XX-3-1-485:1-6-DR	Electrically controlled variable attenuator at 1550nm with 1m long, 3mm OD jacketed 8/125 micron unterminated PM fiber on both ends and 40dB return loss. Unit comes with built in stepper motor drive electronics.
14177	DD-100-11-1550-8/125-P-40-XX-3-1-485:1-6-MC/IIC	Electrically controlled variable attenuator at 1550nm with 1m long, 3mm OD jacketed 8/125 micron unterminated PM fiber on both ends and 40dB return loss. Unit to be calibrated at 1550nm and comes with I ² C interface.
14176	DD-100-11-1550-8/125-P-40-XX-3-1-485:1-6-MC/RS232	Electrically controlled variable attenuator at 1550nm with 1m long, 3mm OD jacketed 8/125 micron unterminated PM fiber on both ends and 40dB return loss. Unit to be calibrated at 1550nm and comes with RS/232 interface.
5852	DD-100-11-1550-8/125-P-50-3A3A-1-1-76:1-12-ER=25-PC	Electrically controlled variable attenuator at 1550nm with 1m long, 0.9mm OD jacketed PM fiber with FC/Angle PC connectors on both ends and 50dB return loss. PC: OEM version, no electronics and calibration. ER≤-25dB
9438	DD-100-11-1550-9/125-S-40-3S3S-1-1-485:1-6-MC/RS232	Electrically controlled variable attenuator with 1m long , 0.9mm OD jacketed singlemode fiber with FC/Super PC connectors on both ends and 40dB return loss. Unit to be calibrated at 1550nm and comes with RS232 interface.
11879	DD-100-11-1550-9/125-S-60-3A3A-3-1-485:1-6-MC/RS232-LL	Electrically controlled variable attenuator with 1m long , 3mm OD jacketed singlemode fiber with FC/Angle PC connectors on both ends and 60dB return loss. Unit to be calibrated at 1550nm and comes with RS232 interface. IL≤0.6dB
14166	DD-100-11-850/1300-50/125-M-35-XX-3-1-485:1-6	Electrically controlled variable attenuator at 850/1300nm with 1m long, 3mm OD jacketed 50/125 micron unterminated multimode fiber on both ends and 35dB return loss. Unit comes with TTL compatible home signal.

Ordering Information For Standard Parts: (cont)

Bar Code	Part Number	Description
14167	DD-100-11-850/1300-50/125-M-35-XX-3-1-485:1-6-DR	Electrically controlled variable attenuator at 850nm with 1m long, 3mm OD jacketed 50/125 micron unterminated multimode fiber on both ends and 35dB return loss. Unit comes with built in stepper motor drive electronics.
14169	DD-100-11-850/1300-50/125-M-35-XX-3-1-485:1-6-MC/IIC	Electrically controlled variable attenuator at 850/1300nm with 1m long, 3mm OD jacketed 50/125 micron unterminated multimode fiber on both ends and 35dB return loss. Unit to be calibrated at 850/1300nm and comes with I ² C interface
14168	DD-100-11-850/1300-50/125-M-35-XX-3-1-485:1-6-MC/RS232	Electrically controlled variable attenuator at 850/1300nm with 1m long, 3mm OD jacketed 50/125 micron unterminated multimode fiber on both ends and 35dB return loss. Unit to be calibrated at 850/1300nm and comes with RS232 interface
8342	DD-100-11-850-50/125-M-35-3S3S-1-1-485:1-6-MC/IIC	Electrically controlled variable attenuator at 850nm with 1m long, 0.9mm OD jacketed 50/125 micron multimode fiber with FC/Super PC connectors on both ends and 35dB return loss. Unit to be calibrated at 850nm and comes with I ² C interface
9929	DD-100-11-1550-9/125-S-60-SCSC-1-1-485:1-6-PC-LL	Electrically controlled variable attenuator at 1550nm with 1m long, 0.9mm OD jacketed singlemode fiber with SC/Super PC connectors on both ends and 60dB return loss. IL≤0.6dB , PC: OEM version, no electronics and no calibration

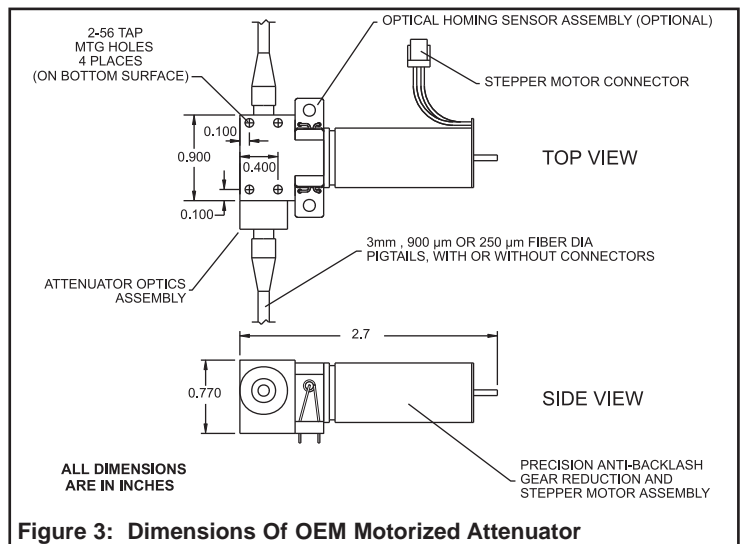
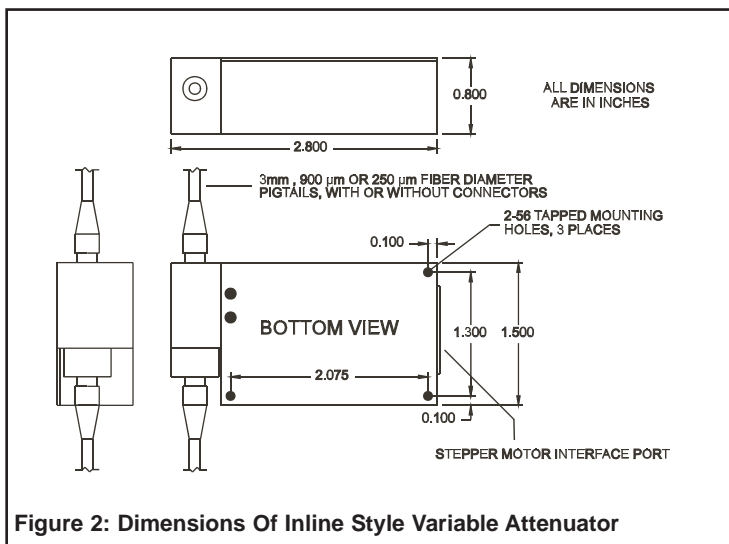
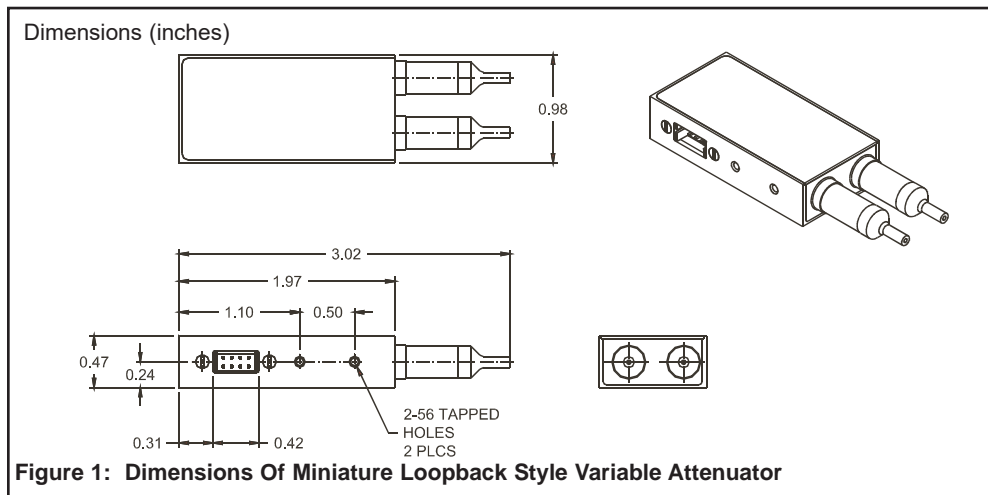

Standard Product Specifications:

SPECIFICATIONS		SM/PM	MM
Available wavelengths ¹		350-2050nm	350-2050nm
Attenuation range ²		I.L. to 60dB	I.L. to 40dB
Attenuation resolution ³		0.01dB	
Insertion loss ⁴	Typical	1.0dB	2.0dB
	Maximum	2.0dB	4.0dB
Wavelength dependence of attenuation ⁵			
from 1300nm to 1550nm		up to 0.3dB	
from 1520nm to 1570nm		up to ±0.1dB	
Polarization dependent loss ⁴	Typical	up to 0.05dB	
	Minimum	up to 0.01dB	
Polarization mode dispersion ⁷		< 0.01 ps	
Return loss ^{4,6}		40, 50 or 60dB	35dB
Speed ⁸		≤ 100ms	
Repeatability of attenuation setting	up to 10dB	0.03dB	
	up to 30dB	0.10dB	
Accuracy ⁹	up to 40dB	± 0.3dB	
	40 to 55dB	± 0.5dB	
	55 to 60dB	± 1.0dB	
Maximum optical power		up to 2 Watts	up to 50mW
Computer interface (MC Version only)		RS232, I ² C or SPI	
Polarization extinction ratio (for PM fiber) ⁴		20, 25 or 30dB	
Weight		(<250grams)	
Power Supply Voltage		5, 6, or 12V	
Power Supply Current (Motor Running)		150mA (Typical)	

NOTES :

- For less than 1290 nm, the specific operating wavelength must be defined. For 1290nm to 1650nm the same unit can be used, although calibration is done only at one to six wavelengths
- Up to 60dB range also available for multimode version upon request
- For attenuation up to 10dB, with 485:1 gear ratio attenuator
- Excluding connectors
- Measured at 23°C and at min. insertion loss
- 60 dB return loss only available for 1290 to 1625 wavelengths
- Measured between 1525nm and 1570nm, temperature between 5°C and 45°C
- For a 3 dB attenuation change, using a 485:1 gear ratio motor, when initially set at 10dB attenuation. Actual performance will vary with initial attenuation and motor gear ratio
- Tested at 23°C

Ordering Examples For Standard Parts:

A customer would like to match the amplitude of two light signals prior to combining them into a single fiber. The wavelengths are 1545 and 1555nm. Due to the flat wavelength response of attenuators, the customer could order a standard 1550nm attenuator for each channel. She would like to have her setup controlled via the serial RS232 ports of a PC. She wants FC connectors on each end of the attenuators and no more than a 40dB return loss. The following part will meet the customer's requirements:

Bar Code	Part Number	Description
9438	DD-100-11-1550-9/125-S-40-3S3S-1-1-485:1-6-MC/RS232	Electrically controlled attenuator with 1m long, 0.9 OD jacketed single mode fiber with FC/super PC connectors on both ends and 40dB return loss. Unit to be calibrated at 1550nm and with RS232 interface.

Ordering Information For Custom Parts:

OZ Optics welcomes the opportunity to provide custom designed products to meet your application needs. As with most manufacturers, customized products do take additional effort so please expect some differences in the pricing compared to our standard parts list. In particular, we will need additional time to prepare a comprehensive quotation, and lead times will be longer than normal. In most cases non-recurring engineering (NRE) charges, lot charges, and a 10 piece minimum order will be necessary. These points will be carefully explained in your quotation, so your decision will be as well informed as possible. We strongly recommend buying our standard products.

Questionnaire For Custom Parts:

1. What is your application?
2. What is your operating wavelength?
3. What is the worst acceptable return loss?
4. What fiber type do you need? What length?
5. What connectors, if any, are you using?
6. Do you have size constraints?
7. Do you require an inline or loopback version?
8. Do you have specific speed or resolution requirements? Compared to a standard unit with a 485:1 gear ratio, either of characteristics can be improved at the expense of the other.
9. What voltage would you like to use to operate the motor? Most users choose 6 volts.
10. Do you want to design and build your own motor control circuitry, or do you want it built into the unit?
11. What optical power level will be used with the attenuator?
12. Will the fiber be subjected to handling once installed, or will it be undisturbed? A 3mm jacket is more rugged than a 900um jacket, but it takes up more space and is less flexible.

Description

**Electrically Controlled Variable Fiber
Optic Attenuator**

Part Number

DD-N-11-W-a/b-F-LB-XY-JD-L-G-V(-CJ)¹(-LL)²

N = 100 for inline style

600 for standard size loopback style
650 for miniature size loopback style

W = Wavelength: Specify in nanometers
(Example: 1550 for 1550nm)

a/b = Fiber core/cladding sizes, in microns

9/125 for 1300/1550nm SM fiber

See Tables 1 to 5 of the OZ *Standard Tables*

http://www.ozoptics.com/ALLNEW_PDF/DTS0079.pdf
datasheet for other standard fiber sizes

F = Fiber type: M = Multimode

S = Singlemode

P = Polarization maintaining

LB = Backreflection level: 40,50 or 60dB for SM & PM only. 60dB is available for 1300nm and 1550nm wavelengths only. 35dB for multimode applications is standard.

X,Y = Connector Code:

3S = Super NTT-FC/PC

3U = Ultra NTT-FC/PC

3A = Angled NTT-FC/PC

8 = AT&T-ST

SC = SC

SCA = Angled SC

See Table 6 of the OZ *Standard Tables*

http://www.ozoptics.com/ALLNEW_PDF/DTS0079.pdf

datasheet for other connectors

CJ = Control Circuit

PC for an OEM assembly without interface port

DR for built in stepper motor drive electronics

MC/SP[®] for intelligent SPI interface

MC/IIC for intelligent I²C interface

MC/RS232 for intelligent RS-232 interface

V = Motor supply voltage: 5,6 or 12 Volt

G = Gear ratio: 485:1 for normal speed, 76:1 for fast speed. Other gear ratios are 141:1, 262:1, 900:1

L = Fiber length, in meters, on each side of the device Example: To order 1 meter of fiber at the input and 7 meters at the output, replace L with 1,7

JD = Fiber jacket type:

1 = 900 micron OD hytrel jacket

3 = 3mm OD Kevlar reinforced PVC cable

See Table 7 of the OZ *Standard Tables*

http://www.ozoptics.com/ALLNEW_PDF/DTS0079.pdf
for other jacket sizes

Note ¹ Unless specified, the unit will be built as a basic version which provides a TTL compatible home signal.

The DD-600 and DD-650 use the blocking style attenuation technique and are recommended only for singlemode or polarization maintaining applications.

Note ² Add LL to the part number for 0.6dB typical insertion losses for 60dB return loss, < 1dB for the rest of the attenuators.

Ordering Examples For Custom Parts:

A customer wants to order an electrically controlled attenuator to be calibrated at 1300nm and 1550 nm, with 3mm OD cabled, 1m long singlemode fiber and FC receptacles on both ends with 50dB back reflection and low loss. He wants to communicate with the unit through an RS232 interface and wants to use 6V for the motor supply voltage and a 485:1 gear ratio motor.

The OZ part number will be: **DD-100-11-1300/1550-9/125-S-50-3U3U-3-1-485:1-6-MC/RS232-LL (LL<1dB)**

Frequently Asked Questions (FAQs):

Q: Can I use Labview to communicate with the unit?

A: Yes. Contact OZ Optics for detailed application notes.

Q: How much is the current consumption (mA)?

A: It depends on the motor and supply voltage. Please contact OZ Optics for detailed application notes.

Q: How many different wavelengths can be calibrated into a single unit?

A: Normally the unit is calibrated for only one wavelength. However on request the unit can be calibrated for as many as five wavelengths (up to 60dB attenuation) or six wavelengths (up to 50dB attenuation).

Q: Can you provide an interface software to allow PC control?

A: Yes, we can. We do have Windows based interface software (For Windows 98 or later versions).

Q: How often should the unit be re-calibrated?

A: We recommend re-calibration every year.

Q: Can I supply 5V to the motor instead of 6V?

A: Yes, but the motor will have to be run more slowly.

Q: Does the attenuation stay constant during a power outage?

A: Yes, it does.

Q: Can a DD-...-MC unit work with both a 12V or 6V motor supply voltage?

A: If the unit is ordered for 6V, it can work with either supply voltage. However, if the unit is ordered for 12V it can only work with a 12V supply.

Q: Can I get the configuration information from the attenuator through an IIC interface?

A: No, you can only get that information if you have an RS232 interface. However you can read the operating status from the IIC interface.

Q: What advantages or disadvantages does the beam blocking version have over the neutral density versions?

A: The beam blocking technique is naturally suited for high power applications, and can achieve greater attenuation levels. The neutral density version show less mode dependence or modal noise in multimode applications.

Q: What do you mean by mode dependence and modal noise?

A: The term multimode means there is more than one path for light to travel inside a single fiber. These paths are known as modes. It does not mean the unit consists of multiple fibers in a bundle. When coherent laser light is coupled into multimode fiber, the output shows speckles. Bending the fiber causes the speckle pattern to change. If the losses in a system depend on which modes are excited, then changing the modes excited in the fiber changes the output power. This is known as modal noise. If the source being used is an LED, then one does not see speckles, and modal noise is not an issue. However, for laser sources, modal noise is an issue.

When blocking style attenuators are used with multimode fiber, some modes are blocked, while others are transmitted. This can produce 1dB or greater modal noise fluctuations with coherent sources. A variable attenuator using a neutral density filter is not as strongly affected by modal noise. However, neutral density filter attenuators offer lower attenuation range (around 40dB) and can only handle about 50mW of power.

Q: I ordered an attenuator with 60dB return loss but when I measured it my return losses are higher. Why?

A: If you ordered an attenuator with 60dB return loss with connectors, the back reflection will depend on what grade of connector you selected for your fibers. Typically only angle polished (APC) style connectors will give the desired return losses. The device itself has 60dB return loss (i.e. if you cut off the connectors and measured the return loss you will see it above 60dB) but if you picked only Super PC finish connectors you may only see from 40 to 45dB. return losses.

Application Notes

Sample Application #1

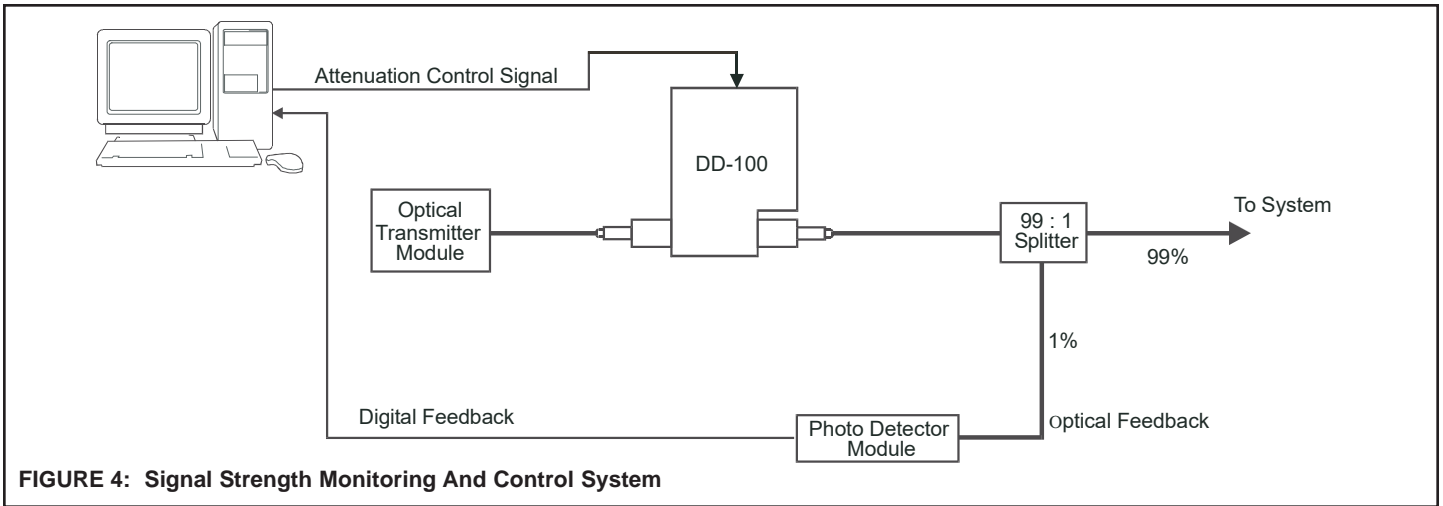

FIGURE 4: Signal Strength Monitoring And Control System

As illustrated in Figure 4 above, light from a transmission module is sent through a DD style attenuator before entering the transmission line. A 99:1 splitter is used to tap off a small monitor signal. This signal is measured with a photodiode module, which produces a digital representation of the light intensity. Based on this feedback, the computer adjusts the attenuator to set the output signal at the optimum intensity.

Sample Application #2

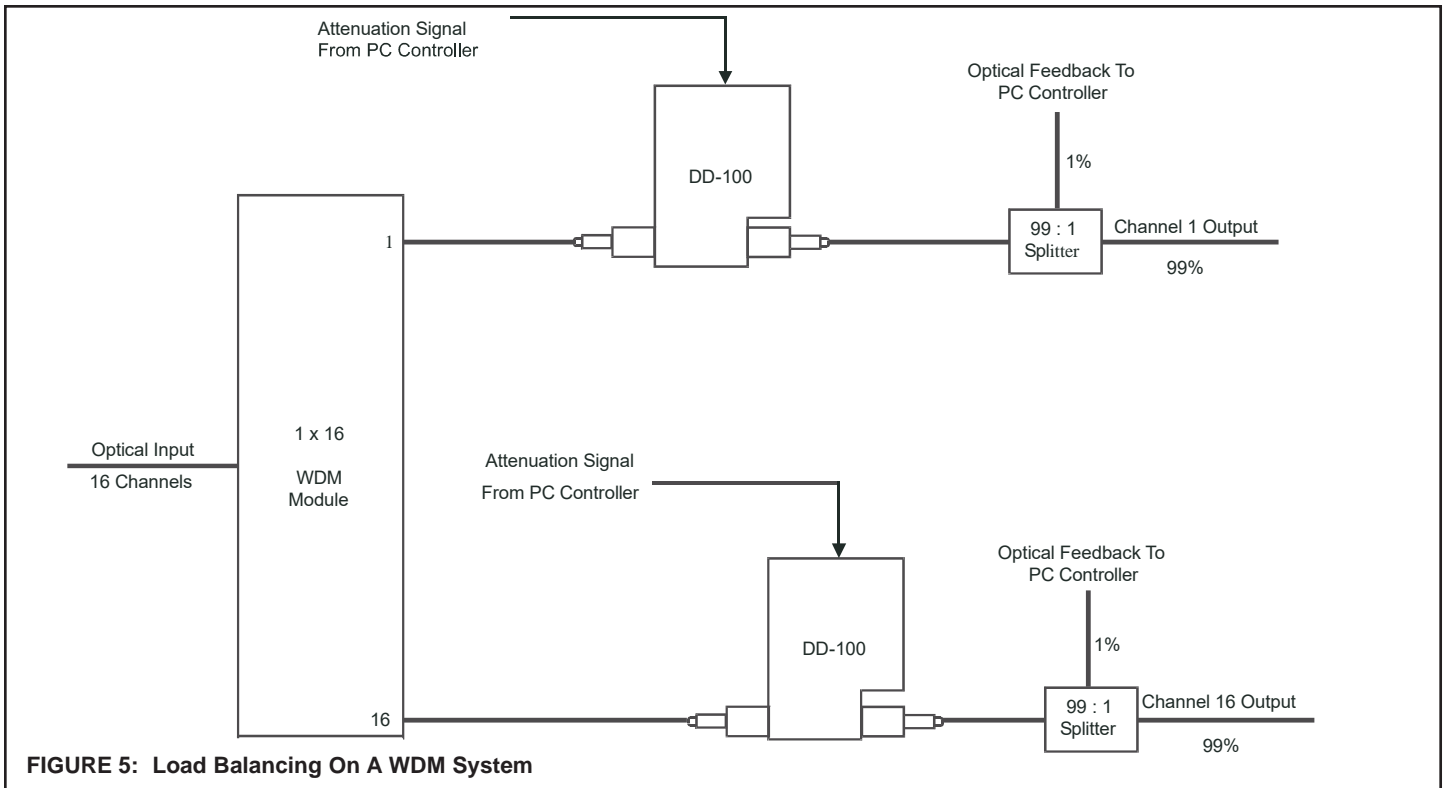

FIGURE 5: Load Balancing On A WDM System

Multiplexed light from a trunk line is demultiplexed into individual signals as shown in Figure 5. They are of different intensities. The signals have to be balanced to avoid saturating any of the receivers. DD style attenuators are inserted between the WDM and the receiver modules. Whenever a receiver module is saturated, a signal is sent to the control computer to increase the attenuation to that module. Whenever the signal becomes too low, the control computer decreases the attenuation.