

REV. NO.		REVISIONS	DATE	APPROVED
		DESCRIPTION		

0.5mm PITCH ADJUSTER,
1.27mm HEX SOCKET
(HEX KEY SUPPLIED)

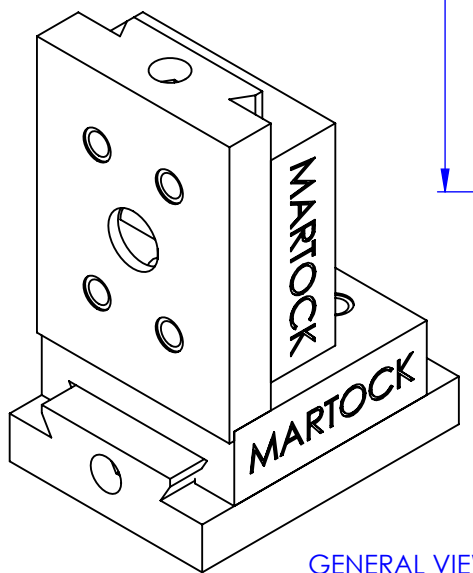
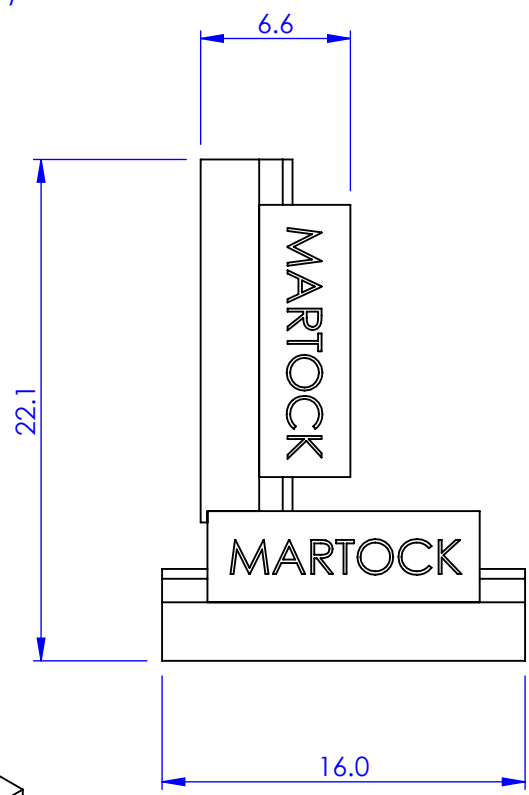
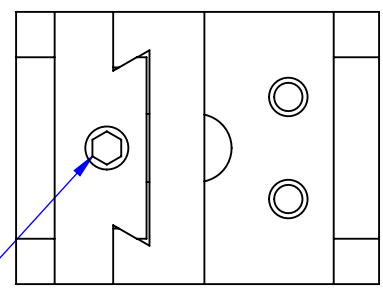

GENERAL VIEW
SCALE: 3:1

4 HOLES TAPPED M1.6
(SAME ON BOTTOM PLATE)

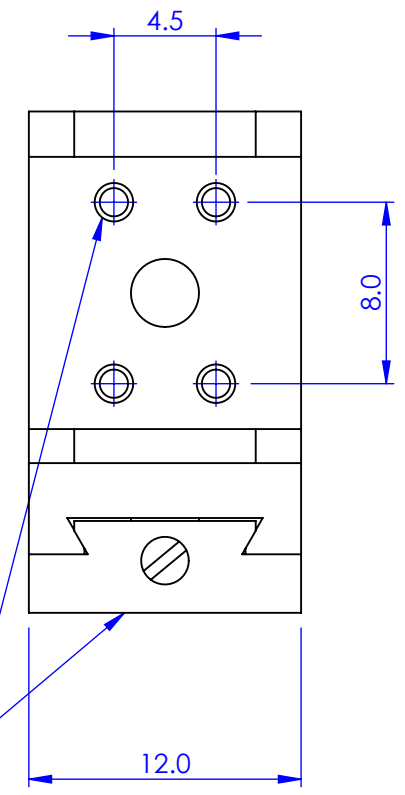

BOTH AXES ±3mm OF TRAVEL

PROPRIETARY AND CONFIDENTIAL
COPYRIGHT ELLIOT SCIENTIFIC Ltd.
THE INFORMATION CONTAINED IN THIS
DRAWING IS THE SOLE PROPERTY OF
ELLIOT SCIENTIFIC LTD. REPRODUCTION
IN PART OR AS A WHOLE WITHOUT WRITTEN
PERMISSION IS PROHIBITED.

DIMENSIONS ARE IN mm
GENERAL TOLERANCES: ± 0.1
ANGULAR TOLERANCES: ±
SURFACE FINISH:
ALL BURRS, SHARP EDGES
AND CORNERS TO BE
REMOVED

NAME	DATE
AUTHOR GW	13/05/2010
CHECKED --	--
MATERIAL CU ALLOY, STAINLESS STEEL	
FINISH --	
DO NOT SCALE DRAWING	

Elliot Scientific

TITLE
XZ MICROPOSITIONER

SIZE **A4** DWG. NO. **MDE268**

SCALE:3:1 THIRD ANGLE PROJECTION SHEET 1 OF 1