

REV.	REVISIONS	DATE	APPROVED
	DESCRIPTION		

±1mm X & Y TRAVEL DOVETAIL SLIDES

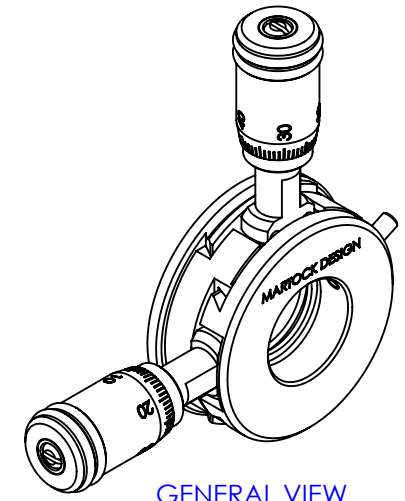

GENERAL VIEW
SCALE: 1:1

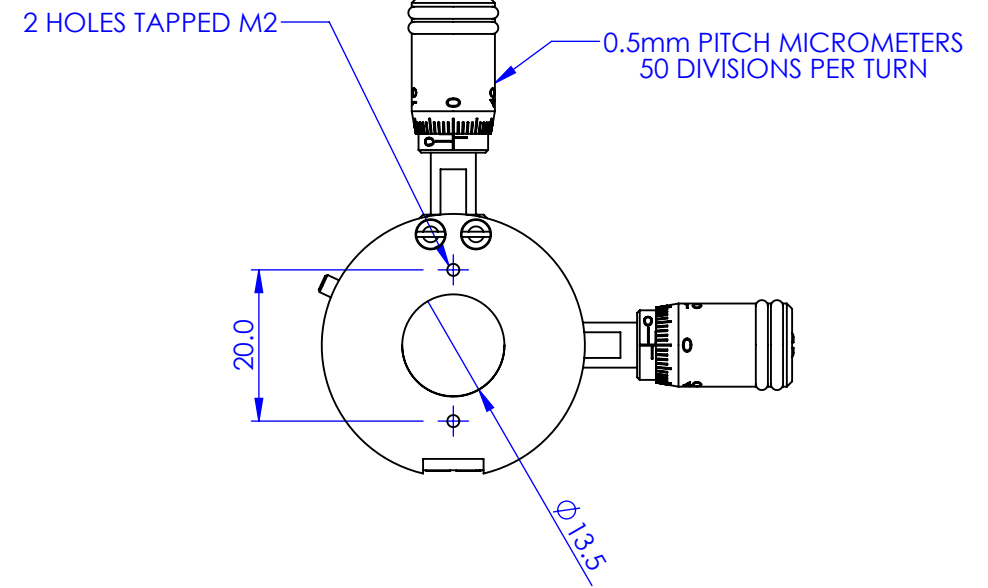
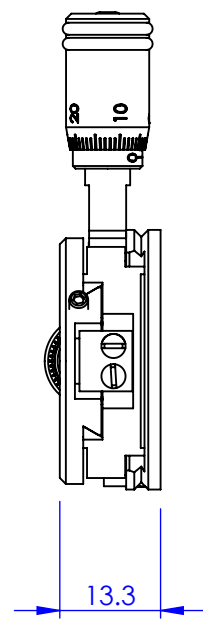
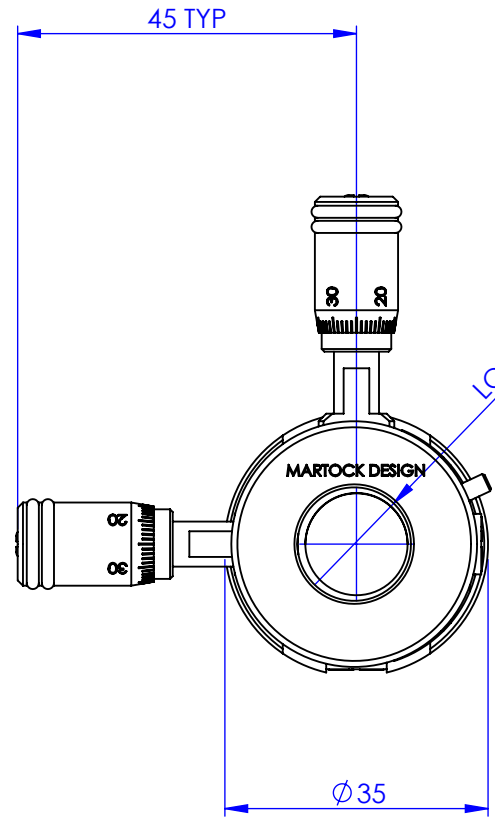

PROPRIETARY AND CONFIDENTIAL
COPYRIGHT ELLIOT SCIENTIFIC Ltd.
 THE INFORMATION CONTAINED IN THIS DRAWING IS THE SOLE PROPERTY OF ELLIOT SCIENTIFIC LTD. REPRODUCTION IN PART OR AS A WHOLE WITHOUT WRITTEN PERMISSION IS PROHIBITED.

DIMENSIONS ARE IN mm
 GENERAL TOLERANCES: ± 0.1
 ANGULAR TOLERANCES: ±
 SURFACE FINISH:
 ALL BURRS, SHARP EDGES
 AND CORNERS TO BE
 REMOVED

NAME	DATE
AUTHOR GW	25/05/2010
CHECKED --	--
MATERIAL	
STAINLESS STEEL	
AL. ALLOY/AL. BRONZE	
FINISH	
--	
DO NOT SCALE DRAWING	

		TITLE	
		PRECISION XY MICROPOSITIONER	
SIZE	DWG. NO.		
A4	MDE251M-15		
SCALE: 1:1		THIRD ANGLE PROJECTION	
		SHEET 1 OF 1	